

Exploded view

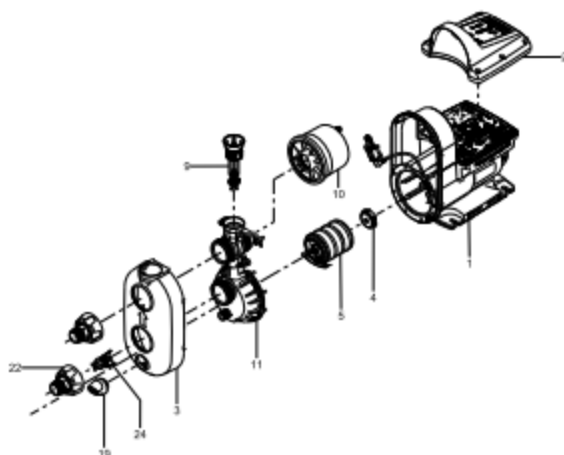

TM06 3306 5114

Materials

Pos.	Component name	Material
1	Combined pump and stator housing	Aluminium, Composite and EN 1.4301 / AISI 304
2	Control box cover	Composite
3	Pump cover	Composite
4	Shaft seal	Carbon/Ceramic
5	Chamber stack (four stages)	Composite
9	Non-return valve, outlet	Composite
10	Tank complete	Composite, Butyl and EN 1.4301/AISI 304
11	Connection part	Composite
19	Drain plug	Composite
22	Thread R 1" / NPT 1"	Composite
24	Non-return valve, inlet	Composite

Dimensional sketch

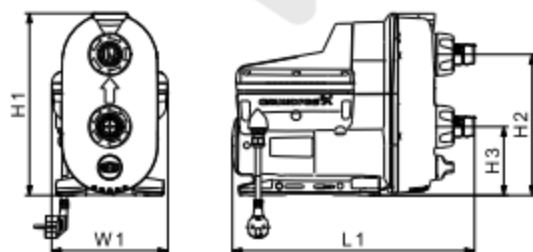

TM06 3305 5114

Type	H1 [mm] [inch]	H2 [mm] [inch]	H3 [mm] [inch]	W1 [mm] [inch]	L1 [mm] [inch]	Weight [kg] [lbs]
SCALA2	302 11.9	234 9.2	114 4.5	193 7.6	403 15.9	10 22

Thermal protection

SCALA2 incorporates current- and temperature-dependent motor protection.

Technical data

Type	Voltage [V] and Frequency [Hz]	I _{max} [A] and P ₁ [W]	Thread	Plug	Product number
SCALA2	1 x 208-230 60	2.3 - 2.8 550	NPT 1"	NEMA 6-15P	98562817
SCALA2	1 x 115 60	5 - 5.7 560		IEC type B, NEMA 5-15P	98562818

Operating conditions

Max. ambient temperature:	113°F (45°C) 131°F (55°C) for 1 x 200-240 V, 50 Hz models.
Max. liquid temperature:	113°F (45°C)
Max. system pressure:	145 PSI (10 bar)
Max. inlet pressure:	87 PSI (6 bar)
Max. head:	148 ft (45 m)
Enclosure rating:	NEMA 3
Pumped liquid:	Clean, fresh water and chlorinated water < 300 ppm.

Markings and approvals

Safety approvals



Drinking water approvals



Subject to alterations.

SCALA2



TM06 4538 2515

General description

Grundfos SCALA2 is a fully integrated, self-priming, compact all-in-one water pump for pressure boosting in domestic applications.

SCALA2 incorporates integrated speed control enabling perfect water pressure at the taps, meaning that the pump performance will increase with increasing demand.

SCALA2 can be installed in three easy steps:

1. Connect the pipes.
2. Prime the pump.
3. Plug the pump into the power outlet and the pump will start.

Grundfos SCALA2 has all the components necessary to ensure a comfortable pressure:

- intelligent controller
- integrated speed-controlled drive
- integrated tank
- integrated sensors
- integrated non-return valve.

Features

- Adjustable constant pressure
- Low noise, < 47 dB(A) (in typical use)
- Compact
- Robust and reliable
- Easy installation and self-priming
- Dry-running protection

Applications

Grundfos SCALA2 is designed for pressure boosting in one-family houses and apartments.

We recommend SCALA2 for the following applications:

- pressure boosting of city mains water
- pressure boosting of water from roof tank
- pressure boosting of water from break tank
- pressure boosting of water from ground tank
- water supply from shallow wells (< 26 1/4 ft / 8 m).

Performance

SCALA2 is suitable for houses with up to three floors and eight tapping points.

Accurate sizing of the pump can be based on the pump curve below and local norms and standards.

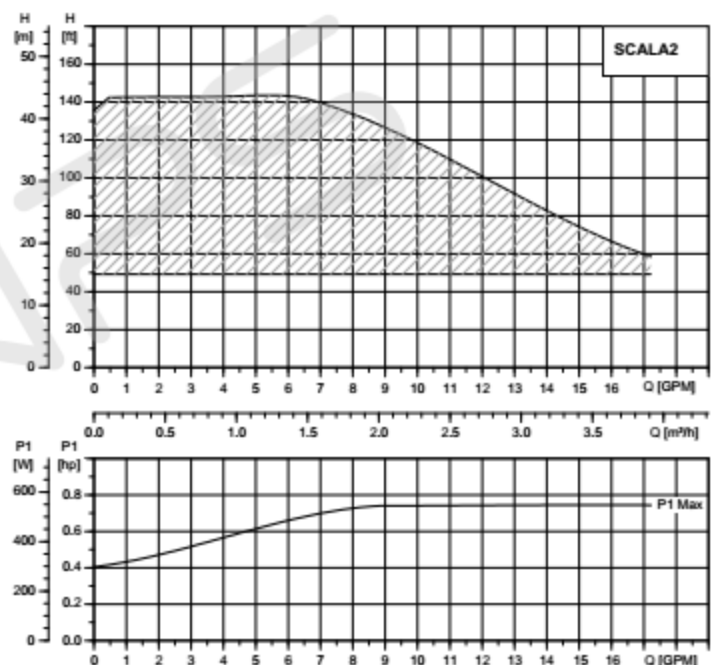

Control panel

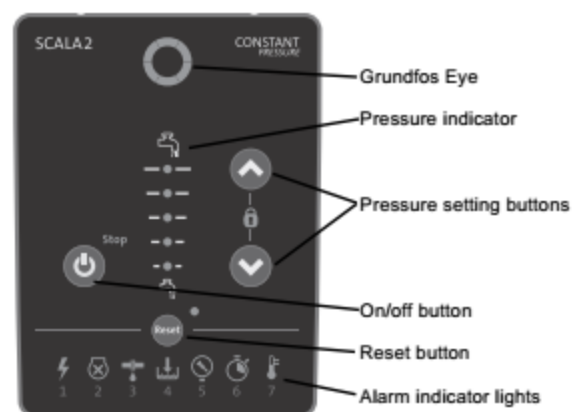

TM06 3301 5114